

MONA200A

Permanent Magnet Synchronous Gearless Traction Machine

永磁同步无齿轮曳引机

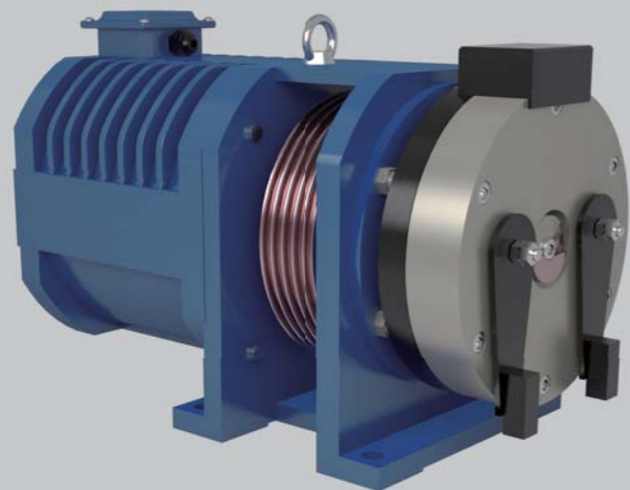

电源电压	Voltage	220V / 380V	曳引比	Roping	2:1
额定载重	Elv.Load	(320~450)kg	额定梯速	Elv.Speed	(0.4~1.0)m/s
曳引轮节径	Sheave Diam	200mm / 240mm	工作制	Duty	S5-40%
防护等级	IP Code	IP41	最大轴静载	Max. Static Load	2500kg
绝缘等级	Ins.Class	F	自重	Weight	160kg
制动器	Brake	DC110V 2.5A			

※ 制动器的电压值表示启动及维持电压。 Brake voltage corresponds to its Start&Sustaining voltage.

安装尺寸图 DIMENSIONS

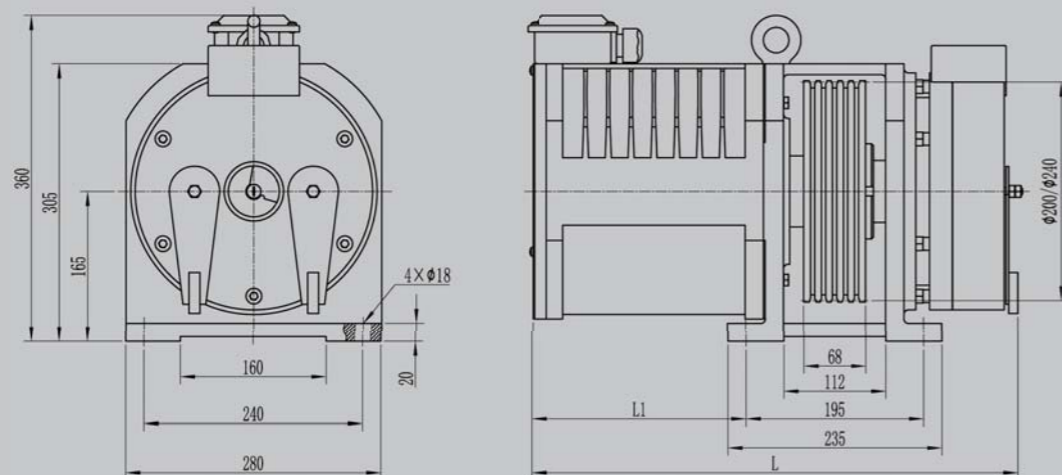

规格表 SPEC.SHEET

型号	规格	额定载重	额定梯速	曳引轮节径	曳引轮绳槽	电源电压	额定电流	额定功率	额定转速	额定频率	额定转矩	电机极数	L	L1	切口角	
Type	Spec.	Elv. Load	Elv. Speed	Sheave Dia.	Sheave Groove	Voltage	Current	Power	Speed	Freq.	Torque	Poles	mm	mm	β Angle	
		kg	m/s	mm		V	A	kW	r/min	Hz	N·m		mm	mm	°	
MONA200A	320-0.4A	320	0.4	200	3×Φ8×12	220	5	0.9	76	10.1	110	16	470	170		
						380	3									
MONA200A	320-0.5A	320	0.5		3×Φ8×12	220	7	1.1	95	12.7	110	16	470	170		
						380	5									
MONA200A	320-0.63A	320	0.63		3×Φ8×12	220	7	1.4	120	16.0	110	16	470	170		
						380	5									
MONA200A	320-1.0A	320	1.0		3×Φ8×12	220	10	2.2	191	25.5	110	16	470	170		
						380	6									
MONA200A	400-0.4A	400	0.4		200	4×Φ8×12	220	6	1.1	76	10.1	140	16	470		170
							380	4								
MONA200A	400-0.5A	400	0.5			4×Φ8×12	220	9	1.4	95	12.7	140	16	470		170
							380	6								
MONA200A	400-0.63A	400	0.63	4×Φ8×12		220	9	1.8	120	16.0	140	16	470	170		
						380	6									
MONA200A	400-1.0A	400	1.0	4×Φ8×12		220	13	2.8	191	25.5	140	16	470	170		
						380	7									
MONA200A	450-0.4A	450	0.4	200		4×Φ8×12	220	7	1.2	76	10.1	150	16	470	170	
							380	5								
MONA200A	450-0.5A	450	0.5			4×Φ8×12	220	9	1.5	95	12.7	150	16	470	170	
							380	6								
MONA200A	450-0.63A	450	0.63		4×Φ8×12	220	9	1.9	120	16.0	150	16	470	170		
						380	6									
MONA200A	450-1.0A	450	1.0		4×Φ8×12	220	14	3.0	191	25.5	150	16	470	170		
						380	8									
MONA200A	320-0.4B	320	0.4		240	3×Φ8×12	220	6	0.9	64	8.5	130	16	470	170	
							380	4								
MONA200A	320-0.5B	320	0.5			3×Φ8×12	220	7	1.1	80	10.7	130	16	470	170	
							380	5								
MONA200A	320-0.63B	320	0.63	3×Φ8×12		220	7	1.4	100	13.3	130	16	470	170		
						380	5									
MONA200A	320-1.0B	320	1.0	3×Φ8×12		220	10	2.2	159	21.2	130	16	470	170		
						380	6									
MONA200A	400-0.4B	400	0.4	240		4×Φ8×12	220	7	1.1	64	8.5	160	16	470	170	
							380	5								
MONA200A	400-0.5B	400	0.5			4×Φ8×12	220	9	1.3	80	10.7	160	16	470	170	
							380	6								
MONA200A	400-0.63B	400	0.63		4×Φ8×12	220	9	1.7	100	13.3	160	16	470	170		
						380	6									
MONA200A	400-1.0B	400	1.0		4×Φ8×12	220	12	2.7	159	21.2	160	16	470	170		
						380	7									
MONA200A	450-0.4B	450	0.4		240	4×Φ8×12	220	8	1.2	64	8.5	180	16	560	240	
							380	5								
MONA200A	450-0.5B	450	0.5			4×Φ8×12	220	10	1.5	80	10.7	180	16	560	240	
							380	6								
MONA200A	450-0.63B	450	0.63	4×Φ8×12		220	9	1.9	100	13.3	180	16	560	240		
						380	6									
MONA200A	450-1.0B	450	1.0	4×Φ8×12		220	13	3.0	159	21.2	180	16	560	240		
						380	8									

注 Remark:

- 1、本机用于无机房。 The machine is used for machine roomless.
- 2、样本切口角为推荐值，可根据实际工况要求选择切口角。 The above is recommended value of cut angle, it's optional according to practical condition.