

MGD120

Permanent Magnet Synchronous Gearless Traction Machine-Belt Type
 永磁同步无齿轮钢带曳引机

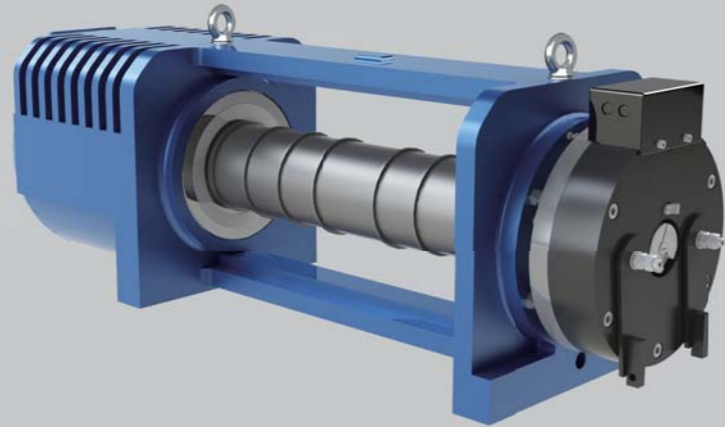

电源电压	Voltage	380V	曳引比	Roping	2:1
额定载重	Elv.Load	(1150~1600)kg	额定梯速	Elv.Speed	(1.0~1.75)m/s
钢带轮直径	Sheave Diam	120mm	工作制	Duty	S5-40%
防护等级	IP Code	IP41	最大轴静载	Max. Static Load	5000kg
绝缘等级	Ins.Class	F	自重	Weight	260kg
制动器	Brake	DC110V 2.5A			

※ 制动器的电压值表示启动及维持电压。 Brake voltage corresponds to its Start&Sustaining voltage.

安装尺寸图 DIMENSIONS

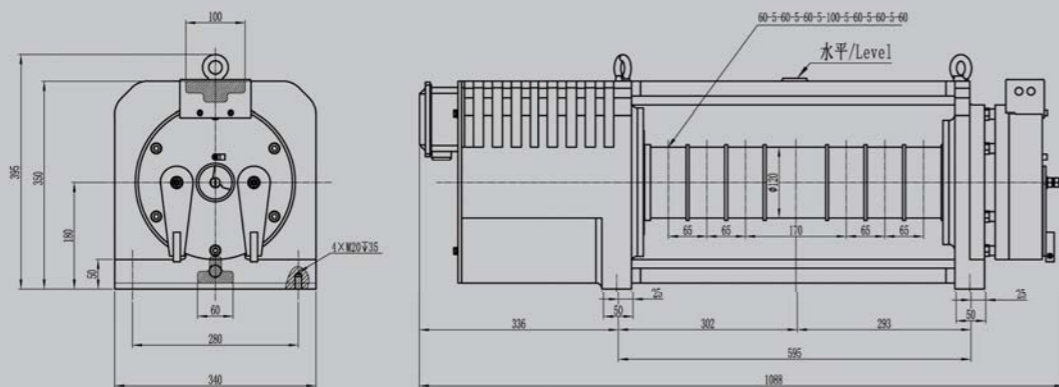

规格表 SPEC.SHEET

型号	规格	额定载重	额定梯速	钢带轮直径	钢带槽	额定电流	额定功率	额定转速	额定频率	额定转矩	电机极数
Type	Spec.	Elv. Load	Elv. Speed	Sheave Dia.	Groove	Current	Power	Speed	Freq.	Torque	Poles
		kg	m/s	mm		A	kW	r/min	Hz	N·m	
MGD120	1150-1.0	1150	1.0	120	4×60	17	7.7	318	31.8	230	12
MGD120	1150-1.5	1150	1.5	120	4×60	24	11.5	477	47.7	230	12
MGD120	1150-1.75	1150	1.75	120	4×60	27	13.4	557	55.7	230	12
MGD120	1250-1.0	1250	1.0	120	6×60	18	8.3	318	31.8	250	12
MGD120	1250-1.5	1250	1.5	120	6×60	26	12.5	477	47.7	250	12
MGD120	1250-1.75	1250	1.75	120	6×60	30	14.6	557	55.7	250	12
MGD120	1350-1.0	1350	1.0	120	6×60	20	9.3	318	31.8	280	12
MGD120	1350-1.5	1350	1.5	120	6×60	29	14.0	477	47.7	280	12
MGD120	1350-1.75	1350	1.75	120	6×60	33	16.3	557	55.7	280	12
MGD120	1600-1.0	1600	1.0	120	6×60	24	11.0	318	31.8	330	12
MGD120	1600-1.5	1600	1.5	120	6×60	34	16.5	477	47.7	330	12
MGD120	1600-1.75	1600	1.75	120	6×60	39	19.2	557	55.7	330	12

注 Remark:

1、本机用于无机房。 The machine is used for machine roomless.