

MCK300

Permanent Magnet Synchronous Gearless Traction Machine

永磁同步无齿轮曳引机

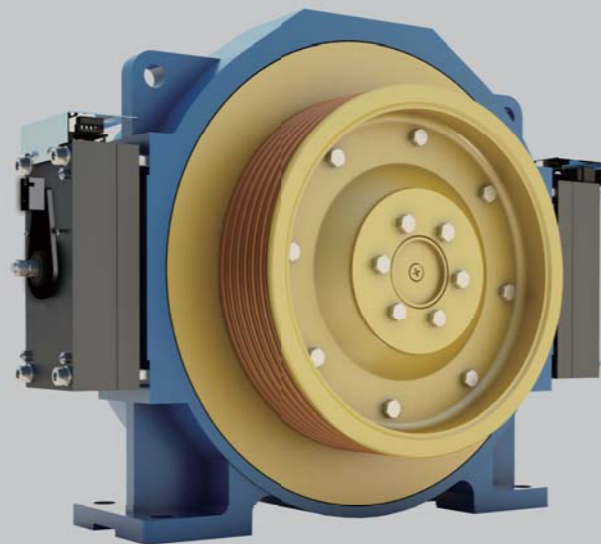

电源电压	Voltage	380V	曳引比	Roping	2:1 / 4:1
额定载重	Elv.Load	(1250~1600)kg	额定梯速	Elv.Speed	(0.5~2.5)m/s
曳引轮节径	Sheave Diam	400mm/450mm/480mm	工作制	Duty	S5-40%
防护等级	IP Code	IP41	最大轴静载	Max. Static Load	6000kg
绝缘等级	Ins.Class	F	自重	Weight	520kg
制动器	Brake	DC110V 2×1.6A			

※ 制动器的电压值表示启动及维持电压。 Brake voltage corresponds to its Start&Sustaining voltage.

安装尺寸图 DIMENSIONS

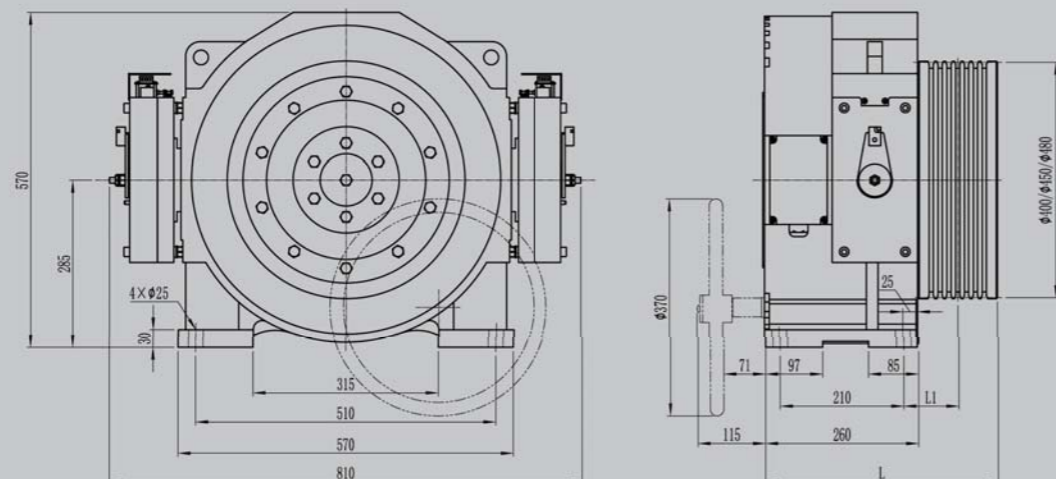

规格表 SPEC.SHEET

型号	规格	额定载重	额定梯速	曳引轮节径	曳引轮绳槽	额定电流	额定功率	额定转速	额定频率	额定转矩	电机极数	L	L1	切口角
Type	Spec.	Elv. Load	Elv. Speed	Sheave Dia.	Sheave Groove	Current	Power	Speed	Freq.	Torque	Poles	mm	mm	β Angle
		kg	m/s	mm		A	kW	r/min	Hz	N·m				°
Roping 曳引比 2:1														
MCK300	1250-0.5	1250	0.5	400	6×Φ10×15	13	4.3	48	12.8	850	32	381	86	
MCK300	1250-0.63	1250	0.63	400	6×Φ10×15	13	5.3	60	16.0	850	32	381	86	
MCK300	1250-1.0	1250	1.0	400	6×Φ10×15	20	8.5	95	25.3	850	32	381	86	
MCK300	1250-1.5	1250	1.5	400	6×Φ10×15	34	12.7	143	38.1	850	32	381	86	
MCK300	1250-1.6	1250	1.6	400	6×Φ10×15	34	13.6	153	40.8	850	32	381	86	
MCK300	1250-1.75	1250	1.75	400	6×Φ10×15	34	14.9	167	44.5	850	32	381	86	
MCK300	1250-2.0	1250	2.0	400	6×Φ10×15	38	17.0	191	50.9	850	32	381	86	
MCK300	1250-2.5	1250	2.5	480	7×Φ10×15	45	21.3	199	53.1	1020	32	381	86	
MCK300	1350-0.5A	1350	0.5	400	7×Φ10×15	14	4.6	48	12.8	920	32	381	86	
MCK300	1350-0.63A	1350	0.63	400	7×Φ10×15	14	5.8	60	16	920	32	381	86	
MCK300	1350-1.0A	1350	1.0	400	7×Φ10×15	21	9.2	95	25.3	920	32	381	86	
MCK300	1350-1.5A	1350	1.5	400	7×Φ10×15	36	13.8	143	38.1	920	32	381	86	
MCK300	1350-1.6A	1350	1.6	400	7×Φ10×15	36	14.7	153	40.8	920	32	381	86	
MCK300	1350-1.75A	1350	1.75	400	7×Φ10×15	36	16.1	167	44.5	920	32	381	86	
MCK300	1350-2.0A	1350	2.0	400	7×Φ10×15	40	18.4	191	50.9	920	32	381	86	
MCK300	1350-2.5	1350	2.5	480	7×Φ10×15	52	22.9	199	53.1	1100	32	381	86	
MCK300	1600-0.5A	1600	0.5	400	7×Φ10×15	18	5.6	48	12.8	1110	32	381	86	
MCK300	1600-0.63A	1600	0.63	400	7×Φ10×15	18	7.0	60	16	1110	32	381	86	
MCK300	1600-1.0A	1600	1.0	400	7×Φ10×15	26	11.0	95	25.3	1110	32	381	86	
MCK300	1600-1.5A	1600	1.5	400	8×Φ10×15	41	16.6	143	38.1	1110	32	396	93.5	
MCK300	1600-1.6A	1600	1.6	400	8×Φ10×15	41	17.8	153	40.8	1110	32	396	93.5	
MCK300	1600-1.75A	1600	1.75	400	8×Φ10×15	41	19.4	167	44.5	1110	32	396	93.5	
MCK300	1600-2.0A	1600	2.0	400	8×Φ10×15	47	22.2	191	50.9	1110	32	396	93.5	
MCK300	1350-0.5B	1350	0.5	450	7×Φ10×15	14	4.5	42	11.2	1030	32	381	86	
MCK300	1350-0.63B	1350	0.63	450	7×Φ10×15	14	5.7	53	14.1	1030	32	381	86	
MCK300	1350-1.0B	1350	1.0	450	7×Φ10×15	22	9.2	85	22.7	1030	32	381	86	
MCK300	1350-1.5B	1350	1.5	450	7×Φ10×15	35	13.7	127	33.9	1030	32	381	86	
MCK300	1350-1.6B	1350	1.6	450	7×Φ10×15	35	14.7	136	36.3	1030	32	381	86	
MCK300	1350-1.75B	1350	1.75	450	7×Φ10×15	35	16.1	149	39.7	1030	32	381	86	
MCK300	1350-2.0B	1350	2.0	450	7×Φ10×15	38	18.3	170	45.3	1030	32	381	86	
MCK300	1600-0.5B	1600	0.5	450	7×Φ10×15	16	5.1	42	11.2	1170	32	381	86	
MCK300	1600-0.63B	1600	0.63	450	7×Φ10×15	16	6.5	53	14.1	1170	32	381	86	
MCK300	1600-1.0B	1600	1.0	450	7×Φ10×15	24	10.4	85	22.7	1170	32	381	86	
MCK300	1600-1.5B	1600	1.5	450	8×Φ10×15	40	15.6	127	33.9	1170	32	396	93.5	
MCK300	1600-1.6B	1600	1.6	450	8×Φ10×15	40	16.7	136	36.3	1170	32	396	93.5	
MCK300	1600-1.75B	1600	1.75	450	8×Φ10×15	40	18.3	149	39.7	1170	32	396	93.5	
MCK300	1600-2.0B	1600	2.0	450	8×Φ10×15	45	20.8	170	45.3	1170	32	396	93.5	
Roping 曳引比 4:1														
MCK300	3000-0.5A	3000	0.5	400	7×Φ10×15	24	10.1	95	25.3	1020	32	381	86	
MCK300	3000-1.0A	3000	1.0	400	8×Φ10×15	45	20.4	191	50.9	1020	32	396	93.5	
MCK300	3000-0.5B	3000	0.5	450	7×Φ10×15	23	9.5	85	22.7	1070	32	381	86	
MCK300	3000-1.0B	3000	1.0	450	7×Φ10×15	42	19.0	170	45.3	1070	32	381	86	
MCK300	3000-0.5C	3000	0.5	480	6×Φ10×15	25	9.6	80	21.3	1150	32	381	86	
MCK300	3000-1.0C	3000	1.0	480	6×Φ10×15	42	19.1	159	42.4	1150	32	381	86	

注 Remark:

- 1、本机亦可用于无机房。 The machine can also be used for machine roomless.
- 2、样本切口角为推荐值，可根据实际工况要求选择切口角度。 The above is recommended value of cut angle, it's optional according to practical condition.

95

根据工况