

MCK200 前盘车

Front-handwheel

Permanent Magnet Synchronous Gearless Traction Machine

永磁同步无齿轮曳引机

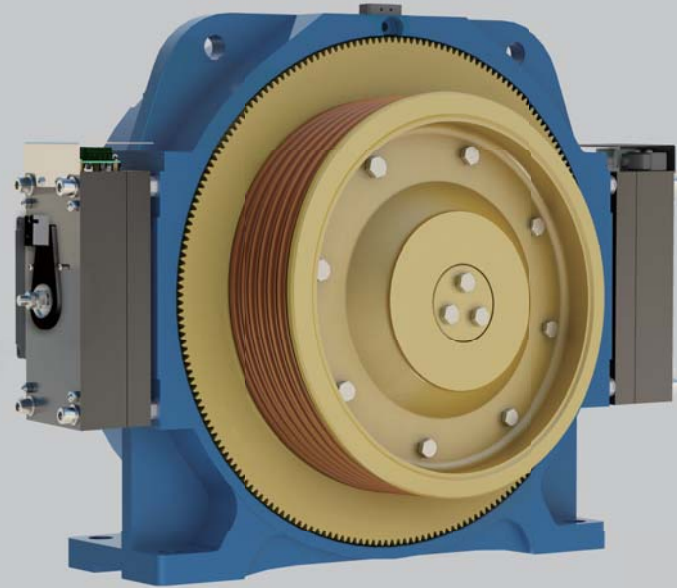

电源电压	Voltage	380V	曳引比	Roping	2:1
额定载重	Elv.Load	(800~1150)kg	额定梯速	Elv.Speed	(0.5~2.5)m/s
曳引轮节径	Sheave Diam	450mm / 480mm	工作制	Duty	S5-40%
防护等级	IP Code	IP41	最大轴静载	Max. Static Load	4500kg
绝缘等级	Ins.Class	F	自重	Weight	370kg
制动器	Brake	DC110V 2×1.3A			

※ 制动器的电压值表示启动及维持电压。 Brake voltage corresponds to its Start&Sustaining voltage.

安装尺寸图 DIMENSIONS

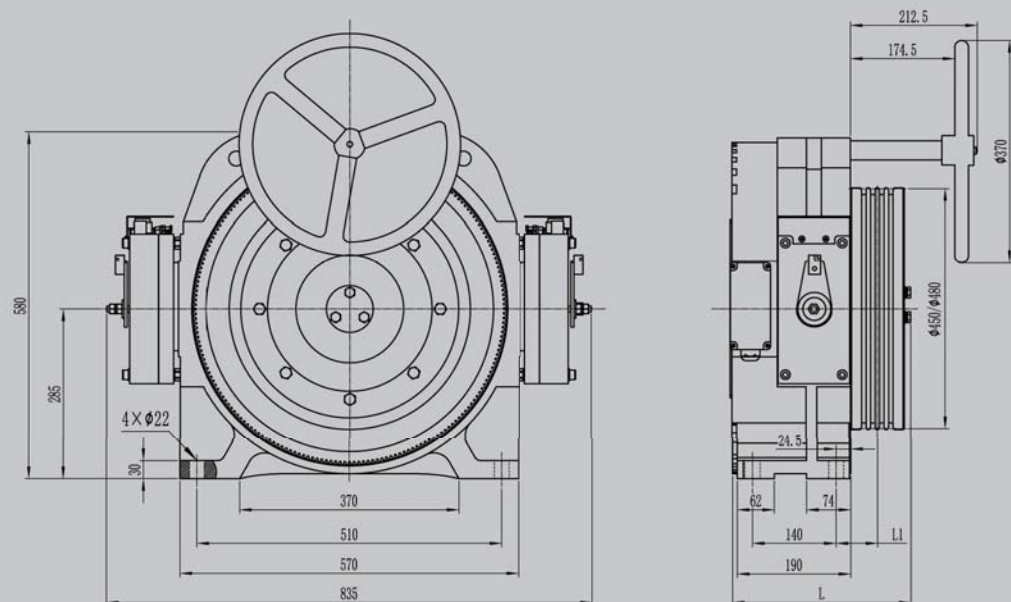

规格表 SPEC.SHEET

型号	规格	额定载重	额定梯速	曳引轮节径	曳引轮绳槽	额定电流	额定功率	额定转速	额定频率	额定转矩	电机极数	L	L1	切口角
Type	Spec.	Elv. Load	Elv. Speed	Sheave Dia.	Sheave Groove	Current	Power	Speed	Freq.	Torque	Poles	mm	mm	β Angle
		kg	m/s	mm		A	kW	r/min	Hz	N·m				°
MCK200	800-1.75	800	1.75	480	5×Φ10×15	22	9.3	139	37.1	640	32	288	69.5	
MCK200	800-2.0	800	2.0	480	5×Φ10×15	23	10.7	159	42.4	640	32	288	69.5	
MCK200	800-2.5	800	2.5	480	5×Φ10×15	30	13.3	199	53.1	640	32	288	69.5	
MCK200	1000-1.75	1000	1.75	480	5×Φ10×15	26	11.6	139	37.1	800	32	288	69.5	
MCK200	1000-2.0	1000	2.0	480	5×Φ10×15	29	13.3	159	42.4	800	32	288	69.5	
MCK200	1000-2.5	1000	2.5	480	6×Φ10×15	36	16.7	199	53.1	800	32	300	75.5	
MCK200	1150-0.5	1150	0.5	450	5×Φ10×15	13	3.6	42	11.2	820	32	288	69.5	
MCK200	1150-0.63	1150	0.63	450	5×Φ10×15	13	4.6	53	14.1	820	32	288	69.5	
MCK200	1150-1.0	1150	1.0	450	5×Φ10×15	18	7.3	85	22.7	820	32	288	69.5	
MCK200	1150-1.5	1150	1.5	450	6×Φ10×15	30	10.9	127	33.9	820	32	300	75.5	
MCK200	1150-1.6	1150	1.6	450	6×Φ10×15	30	11.7	136	36.3	820	32	300	75.5	
MCK200	1150-1.75	1150	1.75	450	6×Φ10×15	30	12.8	149	39.7	820	32	300	75.5	
MCK200	1150-2.0	1150	2.0	450	6×Φ10×15	32	14.6	170	45.3	820	32	300	75.5	
MCK200	1150-2.5	1150	2.5	450	6×Φ10×15	41	18.2	212	56.5	820	32	300	75.5	

注 Remark:

- 1、本机型亦可用于无机房。 The machine can also be used for machine roomless.
- 2、样本切口角为推荐值，可根据实际工况要求选择切口角度。 The above is recommended value of cut angle, it's optional according to practical condition.

95