

# MCK200

Permanent Magnet Synchronous Gearless Traction Machine

永磁同步无齿轮曳引机

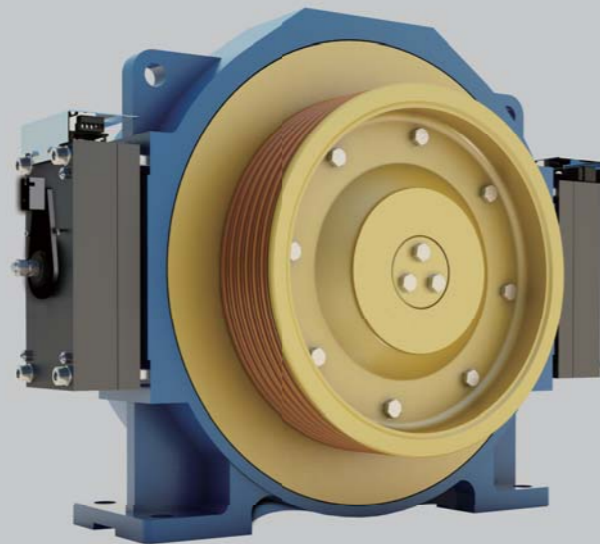

电源电压	Voltage	380V	曳引比	Roping	2:1 / 4:1
额定载重	Elv.Load	(630~1150)kg	额定梯速	Elv.Speed	(0.5~2.5)m/s
曳引轮节径	Sheave Diam	400mm / 450mm	工作制	Duty	S5-40%
防护等级	IP Code	IP41	最大轴静载	Max. Static Load	4000kg
绝缘等级	Ins.Class	F	自重	Weight	350kg
制动器	Brake	DC110V 2×1.3A			

※ 制动器的电压值表示启动及维持电压。 Brake voltage corresponds to its Start&Sustaining voltage.

## 安装尺寸图 DIMENSIONS

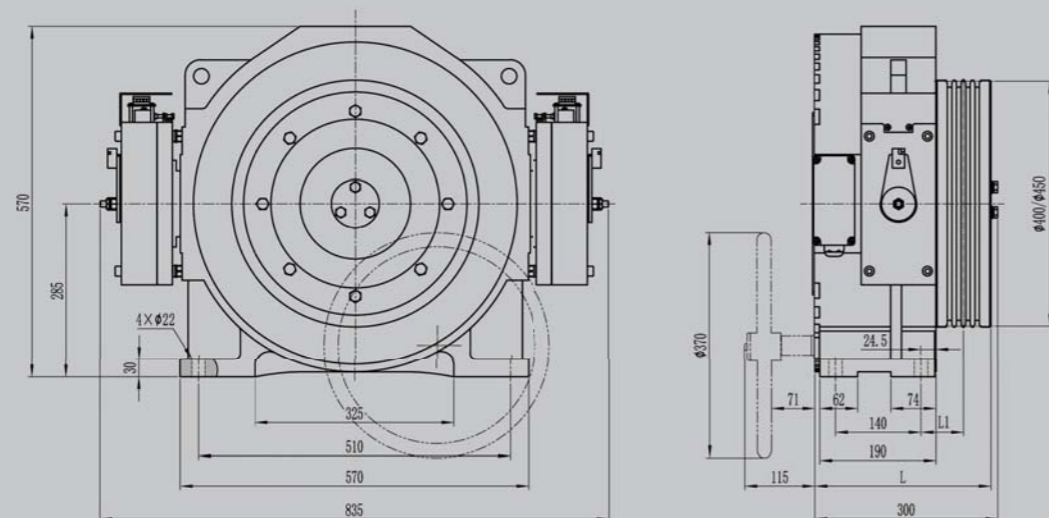

## 规格表 SPEC.SHEET

型号	规格	额定载重	额定梯速	曳引轮节径	曳引轮绳槽	额定电流	额定功率	额定转速	额定频率	额定转矩	电机极数	L	L1	切口角
Type	Spec.	Elv. Load	Elv. Speed	Sheave Dia.	Sheave Groove	Current	Power	Speed	Freq.	Torque	Poles	mm	mm	β Angle
		kg	m/s	mm		A	kW	r/min	Hz	N·m				°
Roping 曳引比 2:1														
MCK200	630-0.5	630	0.5	400	4×Φ10×15	6	2.2	48	12.8	430	32	288	69.5	
MCK200	630-0.63	630	0.63	400	4×Φ10×15	6	2.7	60	16.0	430	32	288	69.5	
MCK200	630-1.0	630	1.0	400	4×Φ10×15	10	4.3	95	25.3	430	32	288	69.5	
MCK200	630-1.5	630	1.5	400	4×Φ10×15	14	6.4	143	38.1	430	32	288	69.5	
MCK200	630-1.6	630	1.6	400	4×Φ10×15	16	6.9	153	40.8	430	32	288	69.5	
MCK200	630-1.75	630	1.75	400	4×Φ10×15	16	7.5	167	44.5	430	32	288	69.5	
MCK200	630-2.0A	630	2.0	400	4×Φ10×15	18	8.6	191	50.9	430	32	288	69.5	
MCK200	630-2.0B	630	2.0	450	4×Φ10×15	18	8.5	170	45.3	480	32	288	69.5	
MCK200	800-0.5	800	0.5	400	5×Φ10×15	8	2.7	48	12.8	540	32	288	69.5	
MCK200	800-0.63	800	0.63	400	5×Φ10×15	8	3.4	60	16.0	540	32	288	69.5	
MCK200	800-1.0	800	1.0	400	5×Φ10×15	12	5.4	95	25.3	540	32	288	69.5	
MCK200	800-1.5	800	1.5	400	5×Φ10×15	18	8.1	143	38.1	540	32	288	69.5	
MCK200	800-1.6	800	1.6	400	5×Φ10×15	20	8.7	153	40.8	540	32	288	69.5	
MCK200	800-1.75	800	1.75	400	5×Φ10×15	20	9.4	167	44.5	540	32	288	69.5	
MCK200	800-2.0A	800	2.0	400	5×Φ10×15	23	10.8	191	50.9	540	32	288	69.5	
MCK200	800-2.0B	800	2.0	450	5×Φ10×15	23	10.7	170	45.3	600	32	288	69.5	
MCK200	800-2.5A	800	2.5	400	6×Φ10×15	28	13.5	239	63.7	540	32	300	75.5	
MCK200	800-2.5B	800	2.5	450	5×Φ10×15	29	13.3	212	56.5	600	32	288	69.5	95
MCK200	1000-0.5	1000	0.5	400	5×Φ10×15	10	3.4	48	12.8	670	32	288	69.5	
MCK200	1000-0.63	1000	0.63	400	5×Φ10×15	10	4.2	60	16.0	670	32	288	69.5	
MCK200	1000-1.0	1000	1.0	400	5×Φ10×15	15	6.7	95	25.3	670	32	288	69.5	
MCK200	1000-1.5	1000	1.5	400	5×Φ10×15	23	10.0	143	38.1	670	32	288	69.5	
MCK200	1000-1.6	1000	1.6	400	5×Φ10×15	26	10.7	153	40.8	670	32	288	69.5	
MCK200	1000-1.75	1000	1.75	400	5×Φ10×15	26	11.7	167	44.5	670	32	288	69.5	
MCK200	1000-2.0A	1000	2.0	400	5×Φ10×15	28	13.4	191	50.9	670	32	288	69.5	
MCK200	1000-2.0B	1000	2.0	450	5×Φ10×15	28	13.4	170	45.3	750	32	288	69.5	
MCK200	1000-2.5A	1000	2.5	400	6×Φ10×15	34	16.8	239	63.7	670	32	300	75.5	
MCK200	1000-2.5B	1000	2.5	450	6×Φ10×15	36	16.6	212	56.5	750	32	300	75.5	
MCK200	1150-0.5	1150	0.5	400	5×Φ10×15	12	3.9	48	12.8	780	32	288	69.5	
MCK200	1150-0.63	1150	0.63	400	5×Φ10×15	12	4.9	60	16.0	780	32	288	69.5	
MCK200	1150-1.0	1150	1.0	400	5×Φ10×15	17	7.8	95	25.3	780	32	288	69.5	
MCK200	1150-1.5	1150	1.5	400	6×Φ10×15	29	11.7	143	38.1	780	32	300	75.5	
MCK200	1150-1.6	1150	1.6	400	6×Φ10×15	29	12.5	153	40.8	780	32	300	75.5	
MCK200	1150-1.75	1150	1.75	400	6×Φ10×15	29	13.6	167	44.5	780	32	300	75.5	
MCK200	1150-2.0	1150	2.0	400	6×Φ10×15	33	15.6	191	50.9	780	32	300	75.5	
Roping 曳引比 4:1														
MCK200	2000-0.5	2000	0.5	400	5×Φ8×12	15	6.7	95	25.3	670	32	288	69.5	根据工况
MCK200	2000-1.0	2000	1.0	400	6×Φ8×12	28	13.4	191	50.9	670	32	288	69.5	

注 Remark:

- 1、本机型亦可用于无机房。 The machine can also be used for machine roomless.
- 2、样本切口角为推荐值，可根据实际工况要求选择切口角度。 The above is recommended value of cut angle, it's optional according to practical condition.