

MCK200

Permanent Magnet Synchronous Gearless Traction Machine

永磁同步无齿轮曳引机

电源电压	Voltage	380V
悬挂比	Roping	2:1
绕绳方式	Wrap	单绕(Single)
额定载重	Elv. Load	630-1150kg
电梯速度	Elv. Speed	0.5-2.5m/s
曳引轮节径	Sheave Diam	400mm/450mm
工作制	Duty	S5-40%ED
起动次数	Starts Per Hour	240st/h
最大轴静载	Max. Static Load	4000kg
自重	Weight	350kg
制动器	Brake	DC110V 2×1.3A
防护等级	IP Code	IP41
绝缘等级	Ins. Class	F

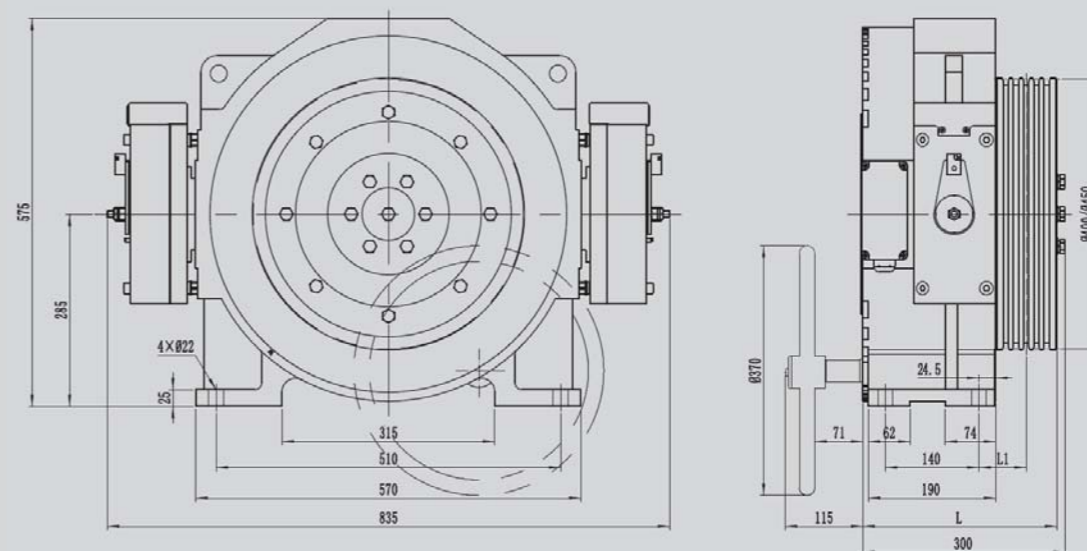

安装尺寸图
DIMENSIONS

规格表 / SPEC. SHEET

型号 Type	规格 Spec	电梯载重 Elv Load kg	额定梯速 Elv Speed m/s	曳引轮直径 Sheave Dia mm	曳引轮绳槽 Sheave Groove	额定电流 Current A	额定功率 Power kW	额定转速 Speed r/min	额定频率 Freq Hz	额定转矩 Torque N.m	电机极数 Poles	L mm	L1 mm	推荐切口角 Undercut Angle °
MCK200	630-0.5A	630	0.5	400	4 × Φ10 × 15	6	2.2	48	12.8	430	32	288	69.5	95
MCK200	630-0.63A	630	0.63	400	4 × Φ10 × 15	6	2.7	60	16.0	430	32	288	69.5	
MCK200	630-1.0A	630	1.0	400	4 × Φ10 × 15	10	4.3	95	25.3	430	32	288	69.5	
MCK200	630-1.5A	630	1.5	400	4 × Φ10 × 15	14	6.4	143	38.1	430	32	288	69.5	
MCK200	630-1.6A	630	1.6	400	4 × Φ10 × 15	16	6.9	153	40.8	430	32	288	69.5	
MCK200	630-1.75A	630	1.75	400	4 × Φ10 × 15	16	7.5	167	44.5	430	32	288	69.5	
MCK200	630-2.0A	630	2.0	400	4 × Φ10 × 15	18	8.6	191	50.9	430	32	288	69.5	
MCK200	630-2.0B	630	2.0	450	4 × Φ10 × 15	18	8.5	170	45.3	480	32	288	69.5	
MCK200	800-0.5A	800	0.5	400	5 × Φ10 × 15	8	2.7	48	12.8	540	32	288	69.5	
MCK200	800-0.63A	800	0.63	400	5 × Φ10 × 15	8	3.4	60	16.0	540	32	288	69.5	
MCK200	800-1.0A	800	1.0	400	5 × Φ10 × 15	12	5.4	95	25.3	540	32	288	69.5	
MCK200	800-1.5A	800	1.5	400	5 × Φ10 × 15	18	8.1	143	38.1	540	32	288	69.5	
MCK200	800-1.6A	800	1.6	400	5 × Φ10 × 15	20	8.7	153	40.8	540	32	288	69.5	
MCK200	800-1.75A	800	1.75	400	5 × Φ10 × 15	20	9.4	167	44.5	540	32	288	69.5	
MCK200	800-2.0A	800	2.0	400	5 × Φ10 × 15	23	10.8	191	50.9	540	32	288	69.5	
MCK200	800-2.0B	800	2.0	450	5 × Φ10 × 15	23	10.7	170	45.3	600	32	288	69.5	
MCK200	800-2.5A	800	2.5	400	6 × Φ10 × 15	28	13.5	239	63.7	540	32	300	75.5	
MCK200	800-2.5B	800	2.5	450	5 × Φ10 × 15	29	13.3	212	56.5	600	32	288	69.5	
MCK200	1000-0.5A	1000	0.5	400	5 × Φ10 × 15	10	3.4	48	12.8	670	32	288	69.5	
MCK200	1000-0.63A	1000	0.63	400	5 × Φ10 × 15	10	4.2	60	16.0	670	32	288	69.5	
MCK200	1000-1.0A	1000	1.0	400	5 × Φ10 × 15	15	6.7	95	25.3	670	32	288	69.5	
MCK200	1000-1.5A	1000	1.5	400	5 × Φ10 × 15	23	10.0	143	38.1	670	32	288	69.5	
MCK200	1000-1.6A	1000	1.6	400	5 × Φ10 × 15	26	10.7	153	40.8	670	32	288	69.5	
MCK200	1000-1.75A	1000	1.75	400	5 × Φ10 × 15	26	11.7	167	44.5	670	32	288	69.5	
MCK200	1000-2.0A	1000	2.0	400	5 × Φ10 × 15	28	13.4	191	50.9	670	32	288	69.5	
MCK200	1000-2.0B	1000	2.0	450	5 × Φ10 × 15	28	13.4	170	45.3	750	32	288	69.5	
MCK200	1000-2.5A	1000	2.5	400	6 × Φ10 × 15	34	16.8	239	63.7	670	32	300	75.5	
MCK200	1000-2.5B	1000	2.5	450	6 × Φ10 × 15	36	16.6	212	56.5	750	32	300	75.5	
MCK200	1150-0.5A	1150	0.5	400	5 × Φ10 × 15	12	3.9	48	12.8	780	32	288	69.5	
MCK200	1150-0.63A	1150	0.63	400	5 × Φ10 × 15	12	4.9	60	16.0	780	32	288	69.5	
MCK200	1150-1.0A	1150	1.0	400	5 × Φ10 × 15	17	7.8	95	25.3	780	32	288	69.5	
MCK200	1150-1.5A	1150	1.5	400	6 × Φ10 × 15	29	11.7	143	38.1	780	32	300	75.5	
MCK200	1150-1.6A	1150	1.6	400	6 × Φ10 × 15	29	12.5	153	40.8	780	32	300	75.5	
MCK200	1150-1.75A	1150	1.75	400	6 × Φ10 × 15	29	13.6	167	44.5	780	32	300	75.5	
MCK200	1150-2.0A	1150	2.0	400	6 × Φ10 × 15	33	15.6	191	50.9	780	32	300	75.5	

注 Remark:

- 1、本机型亦可用于无机房。The machine can also be used for machine roomless.
- 2、制动器可选配交流220V整流模块。Optional AC 220V rectifier for brake.
- 3、样本切口角为推荐值，可根据实际工况要求选择切口角度。The above is recommended value of cut angle, it's optional according to practical condition.