

MCG100

Permanent Magnet Synchronous Gearless Traction Machine

永磁同步无齿轮曳引机

电源电压	Voltage	380V
悬挂比	Roping	2:1
绕绳方式	Wrap	单绕(Single)
额定载重	Elv. Load	320-630kg
电梯速度	Elv. Speed	0.5-1.75m/s
曳引轮节径	Sheave Diam	320mm
工作制	Duty	S5-40%ED
起动次数	Starts Per Hour	240st/h
最大轴静载	Max. Static Load	2500kg
自重	Weight	245kg
制动器	Brake	DC110V 2x1.3A
防护等级	IP Code	IP41
绝缘等级	Ins. Class	F

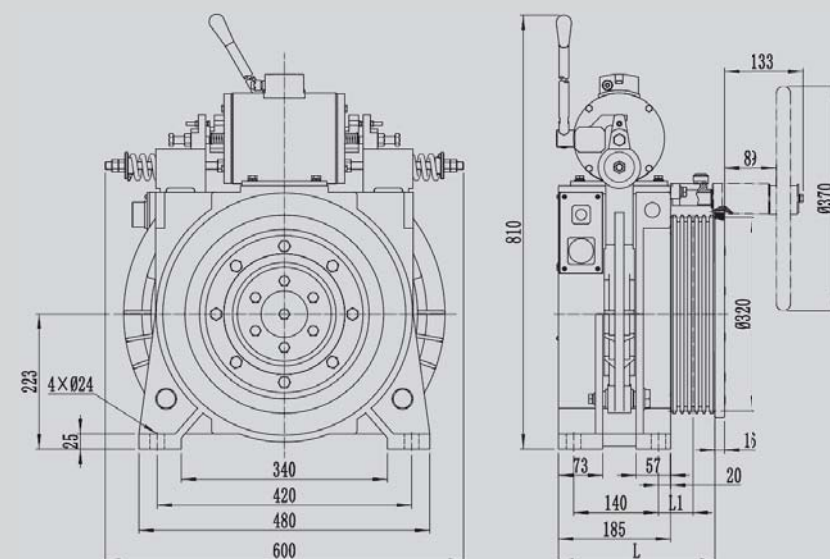

安装尺寸图
DIMENSIONS

规格表 / SPEC. SHEET

型号	规格	电梯载重	额定梯速	曳引轮直径	曳引轮绳槽	额定电流	额定功率	额定转速	额定频率	额定转矩	电机极数	L	L1	推荐切口角
Type	Spec	Elv Load	Elv Speed	Sheave Dia	Sheave Groove	Current	Power	Speed	Freq	Torque	Poles	mm	mm	Undercut Angle
		kg	m/s	mm		A	kW	r/min	Hz	N.m		mm	mm	°
MCG100	320-0.5A	320	0.5	320	3 × Ø8 × 12	3	1.1	60	10.0	180	20	248	52	95
MCG100	320-0.63A	320	0.63	320	3 × Ø8 × 12	3	1.4	75	12.5	180	20	248	52	
MCG100	320-1.0A	320	1.0	320	3 × Ø8 × 12	5	2.2	119	19.8	180	20	248	52	
MCG100	320-1.5A	320	1.5	320	3 × Ø8 × 12	8	3.4	179	29.8	180	20	248	52	
MCG100	450-0.5A	450	0.5	320	4 × Ø8 × 12	5	1.5	60	10.0	240	20	248	52	
MCG100	450-0.63A	450	0.63	320	4 × Ø8 × 12	5	1.9	75	12.5	240	20	248	52	
MCG100	450-1.0A	450	1.0	320	4 × Ø8 × 12	7	3	119	19.8	240	20	248	52	
MCG100	450-1.5A	450	1.5	320	4 × Ø8 × 12	11	4.5	179	29.8	240	20	248	52	
MCG100	450-1.75A	450	1.75	320	4 × Ø8 × 12	11	5.3	209	34.8	240	20	248	52	
MCG100	630-0.5A	630	0.5	320	5 × Ø8 × 12	7	2.1	60	10.0	340	20	258	57	
MCG100	630-0.63A	630	0.63	320	5 × Ø8 × 12	7	2.7	75	12.5	340	20	258	57	
MCG100	630-1.0A	630	1.0	320	5 × Ø8 × 12	10	4.2	119	19.8	340	20	258	57	
MCG100	630-1.5A	630	1.5	320	5 × Ø8 × 12	16	6.4	179	29.8	340	20	258	57	
MCG100	630-1.6A	630	1.6	320	5 × Ø8 × 12	16	6.8	191	31.8	340	20	258	57	
MCG100	630-1.75A	630	1.75	320	5 × Ø8 × 12	16	7.4	209	34.8	340	20	258	57	

注 Remark:

1、本机型亦可用于无机房。The machine can also be used for machine roomless.

2、样本切口角为推荐值，可根据实际工况要求选择切口角度。The above is recommended value of cut angle, it's optional according to practical condition.