

MCG150

Permanent Magnet Synchronous Gearless Traction Machine 永磁同步无齿轮曳引机

电源电压	Voltage	380V
悬挂比	Roping	2:1
绕绳方式	Wrap	单绕(Single)
额定载重	Elv. Load	630-800kg
电梯速度	Elv. Speed	0.5-2.0m/s
曳引轮节径	Sheave Diam	400mm
工作制	Duty	S5-40%ED
起动次数	Starts Per Hour	240st/h
最大轴静载	Max. Static Load	2500kg
自重	Weight	305kg
制动器	Brake	DC110V 2x1.3A
防护等级	IP Code	IP41
绝缘等级	Ins. Class	F

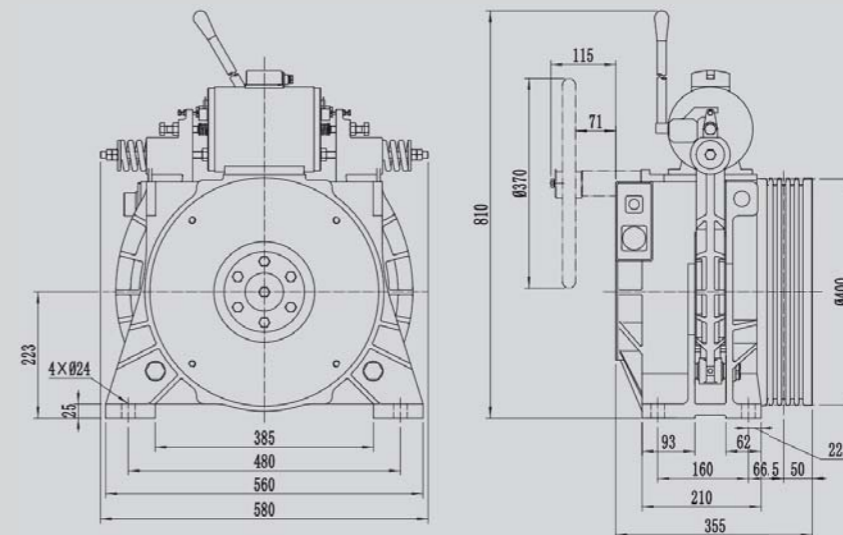

安装尺寸图
DIMENSIONS

规格表 / SPEC. SHEET

型号	规格	电梯载重	额定梯速	曳引轮直径	曳引轮绳槽	额定电流	额定功率	额定转速	额定频率	额定转矩	电机极数	推荐切口角
Type	Spec	Elv Load	Elv Speed	Sheave Dia	Sheave Groove	Current	Power	Speed	Freq	Torque	Poles	Undercut Angle
		kg	m/s	mm		A	kW	r/min	Hz	N.m		°
MCG150	630-0.5A	630	0.5	400	4 × Φ10 × 15	7	2.2	48	8.0	430	20	90
MCG150	630-0.63A	630	0.63	400	4 × Φ10 × 15	7	2.7	60	10.0	430	20	
MCG150	630-1.0A	630	1.0	400	4 × Φ10 × 15	10	4.3	95	15.8	430	20	
MCG150	630-1.5A	630	1.5	400	4 × Φ10 × 15	17	6.4	143	23.8	430	20	
MCG150	630-1.6A	630	1.6	400	4 × Φ10 × 15	17	6.9	153	25.5	430	20	
MCG150	630-1.75A	630	1.75	400	4 × Φ10 × 15	17	7.5	167	27.8	430	20	
MCG150	630-2.0A	630	2.0	400	4 × Φ10 × 15	19	8.6	191	31.8	430	20	
MCG150	800-0.5A	800	0.5	400	5 × Φ10 × 15	9	2.7	48	8.0	540	20	
MCG150	800-0.63A	800	0.63	400	5 × Φ10 × 15	9	3.4	60	10.0	540	20	
MCG150	800-1.0A	800	1.0	400	5 × Φ10 × 15	12	5.4	95	15.8	540	20	
MCG150	800-1.5A	800	1.5	400	5 × Φ10 × 15	21	8.1	143	23.8	540	20	
MCG150	800-1.6A	800	1.6	400	5 × Φ10 × 15	21	8.7	153	25.5	540	20	
MCG150	800-1.75A	800	1.75	400	5 × Φ10 × 15	21	9.4	167	27.8	540	20	
MCG150	800-2.0A	800	2.0	400	5 × Φ10 × 15	23	10.8	191	31.8	540	20	

注 Remark:

- 1、本机型亦可用于无机房。The machine can also be used for machine roomless.
- 2、样本切口角为推荐值，可根据实际工况要求选择切口角度。The above is recommended value of cut angle, it's optional according to practical condition.