



# MCG300A

## Permanent Magnet Synchronous Gearless Traction Machine

### 永磁同步无齿轮曳引机

电源电压	Voltage	380V
悬挂比	Roping	2:1
绕绳方式	Wrap	单绕(Single)
额定载重	Elv. Load	1350-1600kg
电梯速度	Elv. Speed	0.5-2.5m/s
曳引轮节径	Sheave Diam	400mm / 480mm
工作制	Duty	S5-40%ED
起动次数	Starts Per Hour	240st/h
最大轴静载	Max. Static Load	6000kg
自重	Weight	575kg
制动器	Brake	DC110V 2x1.7A
防护等级	IP Code	IP41
绝缘等级	Ins. Class	F

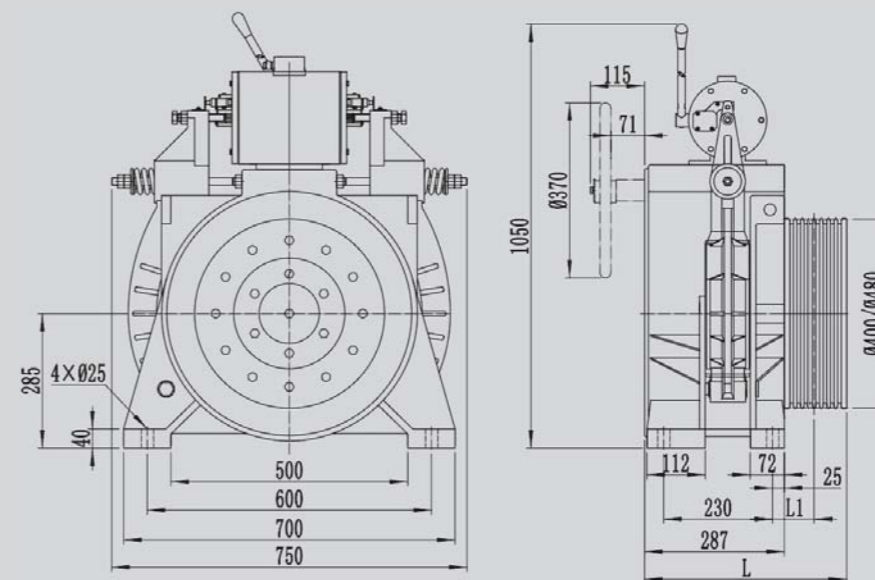

安装尺寸图  
DIMENSIONS

## 规格表 / SPEC. SHEET

型号	规格	电梯载重	额定梯速	曳引轮直径	曳引轮绳槽	额定电流	额定功率	额定转速	额定频率	额定转矩	电机极数	L	L1	推荐切口角
Type	Spec	Elv Load	Elv Speed	Sheave Dia	Sheave Groove	Current	Power	Speed	Freq	Torque	Poles	mm	mm	Undercut Angle
		kg	m/s	mm		A	kW	r/min	Hz	N.m				°
MCG300A	1250-0.5A	1250	0.5	400	6 × Ø10 × 15	13	4.3	48	12.8	850	32	410	86	95
MCG300A	1250-0.63A	1250	0.63	400	6 × Ø10 × 15	13	5.3	60	16.0	850	32	410	86	
MCG300A	1250-1.0A	1250	1.0	400	6 × Ø10 × 15	20	8.5	95	25.3	850	32	410	86	
MCG300A	1250-1.5A	1250	1.5	400	6 × Ø10 × 15	34	12.7	143	38.1	850	32	410	86	
MCG300A	1250-1.6A	1250	1.6	400	6 × Ø10 × 15	34	13.6	153	40.8	850	32	410	86	
MCG300A	1250-1.75A	1250	1.75	400	6 × Ø10 × 15	34	14.9	167	44.5	850	32	410	86	
MCG300A	1250-2.0A	1250	2.0	400	6 × Ø10 × 15	38	17.0	191	50.9	850	32	410	86	
MCG300A	1250-2.5A	1250	2.5	480	7 × Ø10 × 15	45	21.3	199	53.1	1020	32	410	86	
MCG300A	1350-0.5A	1350	0.5	400	7 × Ø10 × 15	14	4.6	48	12.8	920	32	410	86	
MCG300A	1350-0.63A	1350	0.63	400	7 × Ø10 × 15	14	5.8	60	16.0	920	32	410	86	
MCG300A	1350-1.0A	1350	1.0	400	7 × Ø10 × 15	21	9.2	95	25.3	920	32	410	86	
MCG300A	1350-1.5A	1350	1.5	400	7 × Ø10 × 15	36	13.8	143	38.1	920	32	410	86	
MCG300A	1350-1.6A	1350	1.6	400	7 × Ø10 × 15	36	14.7	153	40.8	920	32	410	86	
MCG300A	1350-1.75A	1350	1.75	400	7 × Ø10 × 15	36	16.1	167	44.5	920	32	410	86	
MCG300A	1350-2.0A	1350	2.0	400	7 × Ø10 × 15	40	18.4	191	50.9	920	32	410	86	
MCG300A	1350-2.5A	1350	2.5	480	7 × Ø10 × 15	52	22.9	199	53.1	1100	32	410	86	
MCG300A	1600-0.5A	1600	0.5	400	7 × Ø10 × 15	18	5.6	48	12.8	1110	32	410	86	
MCG300A	1600-0.63A	1600	0.63	400	7 × Ø10 × 15	18	7.0	60	16.0	1110	32	410	86	
MCG300A	1600-1.0A	1600	1.0	400	7 × Ø10 × 15	26	11.0	95	25.3	1110	32	410	86	
MCG300A	1600-1.5A	1600	1.5	400	8 × Ø10 × 15	41	16.6	143	38.1	1110	32	425	93.5	
MCG300A	1600-1.6A	1600	1.6	400	8 × Ø10 × 15	41	17.8	153	40.8	1110	32	425	93.5	
MCG300A	1600-1.75A	1600	1.75	400	8 × Ø10 × 15	41	19.4	167	44.5	1110	32	425	93.5	
MCG300A	1600-2.0A	1600	2.0	400	8 × Ø10 × 15	47	22.2	191	50.9	1110	32	425	93.5	

注 Remark:

- 1、本机型亦可用于无机房。The machine can also be used for machine roomless.
- 2、样本切口角为推荐值，可根据实际工况要求选择切口角度。The above is recommended value of cut angle, it's optional according to practical condition.