

MDD070

Permanent Magnet Synchronous Gearless Traction Machine 永磁同步无齿轮曳引机

电源电压	Voltage	380V
悬挂比	Roping	2:1
绕绳方式	Wrap	单绕(Single)
额定载重	Elv. Load	1350-1600kg
电梯速度	Elv. Speed	1.0-1.75m/s
曳引轮节径	Sheave Diam	430mm
工作制	Duty	S5-40%ED
起动次数	Starts Per Hour	240st/h
最大轴静载	Max. Static Load	4000kg
自重	Weight	650kg
制动器	Brake	AC220V 2x1.0A
防护等级	IP Code	IP41
绝缘等级	Ins. Class	F

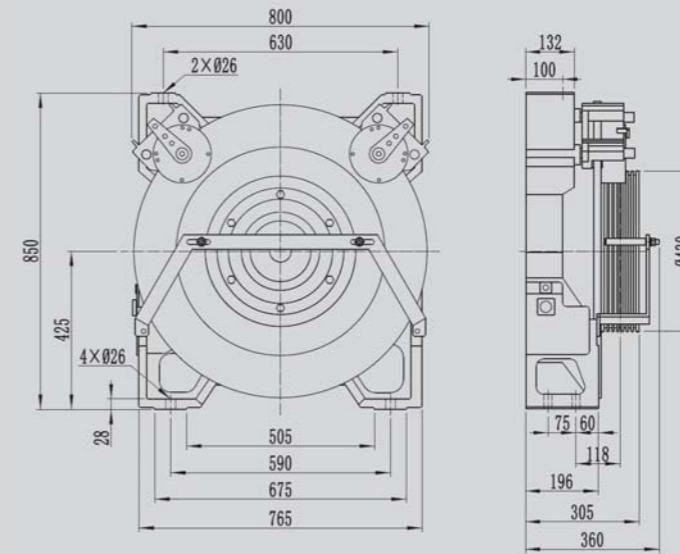

安装尺寸图
DIMENSIONS

规格表 / SPEC. SHEET

型号	规格	电梯载重	额定梯速	曳引轮直径	曳引轮绳槽	额定电流	额定功率	额定转速	额定频率	额定转矩	电机极数	推荐切口角
Type	Spec	Elv Load	Elv Speed	Sheave Dia	Sheave Groove	Current	Power	Speed	Freq	Torque	Poles	Undercut Angle
		kg	m/s	mm		A	kW	r/min	Hz	N.m		°
MDD070	1350-1.0A	1350	1.0	430	7 × Φ10 × 13	22	9.2	89	35.6	990	48	95
MDD070	1350-1.5A	1350	1.5	430	7 × Φ10 × 13	36	13.8	133	53.2	990	48	
MDD070	1350-1.6A	1350	1.6	430	7 × Φ10 × 13	36	14.7	142	56.8	990	48	
MDD070	1350-1.75A	1350	1.75	430	7 × Φ10 × 13	36	16.1	155	62.0	990	48	
MDD070	1600-1.0A	1600	1.0	430	7 × Φ10 × 13	26	11.1	89	35.6	1190	48	
MDD070	1600-1.5A	1600	1.5	430	7 × Φ10 × 13	43	16.6	133	53.2	1190	48	
MDD070	1600-1.6A	1600	1.6	430	7 × Φ10 × 13	43	17.7	142	56.8	1190	48	
MDD070	1600-1.75A	1600	1.75	430	7 × Φ10 × 13	43	19.3	155	62.0	1190	48	

注 Remark:

1、本机型用于无机房。The machine is used for machine roomless.

2、样本切口角为推荐值，可根据实际工况要求选择切口角度。The above is recommended value of cut angle, it's optional according to practical condition.