

MONA200

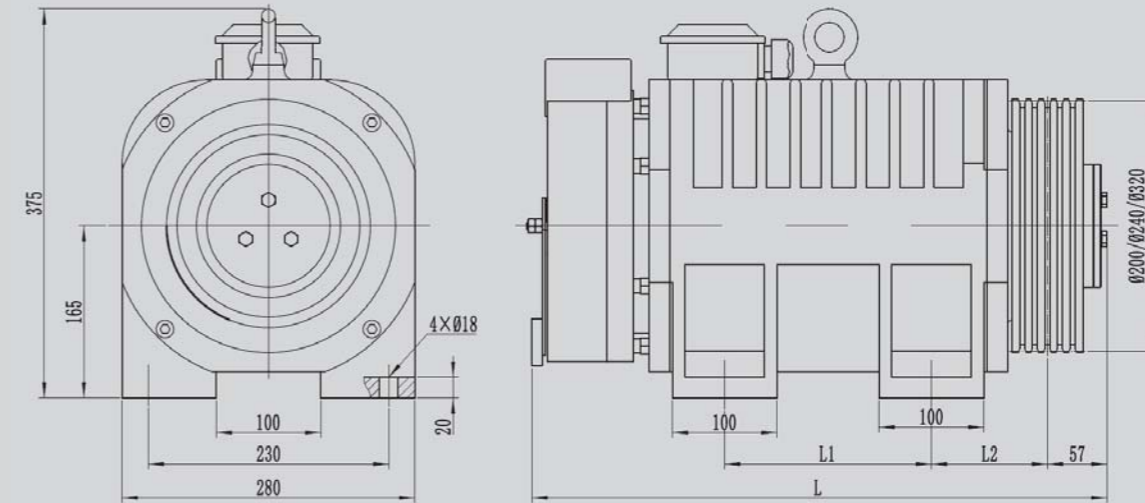

安装尺寸图
DIMENSIONS

Permanent Magnet Synchronous Gearless Traction Machine

永磁同步无齿轮曳引机

电源电压	Voltage	220V / 380V
悬挂比	Roping	2:1 / 1:1
绕绳方式	Wrap	单绕(Single)
额定载重	Elv. Load	320-630kg
电梯速度	Elv. Speed	0.4m/s-1.5m/s
曳引轮节径	Sheave Diam	200mm/240mm/320mm
工作制	Duty	S5-40%ED
起动次数	Starts Per Hour	180st/h
最大轴静载	Max. Static Load	2500kg
自重	Weight	210kg
制动器	Brake	DC110V 2.6A
防护等级	IP Code	IP41
绝缘等级	Ins. Class	F

规格表 / SPEC. SHEET

型号 Type	悬挂比 Roping	规格 Spec	电梯载重 Elv Load kg	额定梯速 Elv Speed m/s	曳引轮直径 Sheave Dia mm	曳引轮绳槽 Sheave Groove	额定电压 Voltage V	额定电流 Current A	额定功率 Power kW	额定转速 Speed r/min	额定频率 Freq Hz	额定转矩 Torque N.m	电机极数 Poles	L	L1	L2	推荐切口角 Undercut Angle °
MONA200	2:1	320-0.4-1	320	0.4	200	3 × Ø8 × 12	220 380	4 2	0.9	76	15.2	110	24	430	100	100.5	90
MONA200	2:1	400-0.4-1	400	0.4	200	4 × Ø8 × 12	220 380	5 3	1.1	76	15.2	140	24	430	100	100.5	
MONA200	2:1	450-0.4-1	450	0.4	200	4 × Ø8 × 12	220 380	6 3	1.2	76	15.2	150	24	430	100	100.5	
MONA200	2:1	320-0.4-2	320	0.4	240	3 × Ø8 × 12	220 380	5 3	0.9	64	12.8	130	24	430	100	100.5	
MONA200	2:1	400-0.4-2	400	0.4	240	4 × Ø8 × 12	220 380	6 3	1.1	64	12.8	160	24	430	100	100.5	
MONA200	2:1	450-0.4-2	450	0.4	240	4 × Ø8 × 12	220 380	7 4	1.2	64	12.8	180	24	430	100	100.5	
MONA200	1:1	320-0.4-3	320	0.4	200	4 × Ø8 × 12	220 380	5 3	0.9	38	7.6	220	24	520	150	110.5	
MONA200	1:1	400-0.4-3	400	0.4	200	5 × Ø8 × 12	220 380	6 4	1.1	38	7.6	270	24	520	150	110.5	
MONA200	1:1	450-0.4-3	450	0.4	200	5 × Ø8 × 12	220 380	7 4	1.2	38	7.6	300	24	520	150	110.5	
MONA200	1:1	320-0.4-4	320	0.4	240	4 × Ø8 × 12	220 380	6 4	0.9	32	6.4	260	24	520	150	110.5	
MONA200	1:1	400-0.4-4	400	0.4	240	5 × Ø8 × 12	220 380	7 4	1.1	32	6.4	320	24	520	150	110.5	
MONA200	1:1	450-0.4-4	450	0.4	240	5 × Ø8 × 12	220 380	8 5	1.2	32	6.4	360	24	570	200	110.5	
MONA200	2:1	320-0.5-1	320	0.5	320	3 × Ø8 × 12	380	4	1.1	60	12.0	170	24	430	100	100.5	
MONA200	2:1	320-0.63-1	320	0.63	320	3 × Ø8 × 12	380	4	1.3	75	15.0	170	24	430	100	100.5	
MONA200	2:1	320-1.0-1	320	1.0	320	3 × Ø8 × 12	380	6	2.1	119	23.8	170	24	430	100	100.5	
MONA200	2:1	400-0.5-1	400	0.5	320	4 × Ø8 × 12	380	5	1.4	60	12.0	220	24	520	150	110.5	
MONA200	2:1	400-0.63-1	400	0.63	320	4 × Ø8 × 12	380	5	1.7	75	15.0	220	24	520	150	110.5	
MONA200	2:1	400-1.0-1	400	1.0	320	4 × Ø8 × 12	380	8	2.7	119	23.8	220	24	520	150	110.5	
MONA200	2:1	450-0.5-1	450	0.5	320	4 × Ø8 × 12	380	6	1.5	60	12.0	240	24	520	150	110.5	
MONA200	2:1	450-0.63-1	450	0.63	320	4 × Ø8 × 12	380	6	1.9	75	15.0	240	24	520	150	110.5	
MONA200	2:1	450-1.0-1	450	1.0	320	4 × Ø8 × 12	380	9	3	119	23.8	240	24	520	150	110.5	
MONA200	2:1	630-0.5-1	630	0.5	320	5 × Ø8 × 12	380	8	2.1	60	12.0	340	24	570	200	110.5	
MONA200	2:1	630-0.63-1	630	0.63	320	5 × Ø8 × 12	380	8	2.7	75	15.0	340	24	570	200	110.5	
MONA200	2:1	630-1.0-1	630	1.0	320	5 × Ø8 × 12	380	11	4.2	119	23.8	340	24	570	200	110.5	
MONA200	2:1	630-1.5-1	630	1.5	320	5 × Ø8 × 12	380	16	6.4	179	35.8	340	24	570	200	110.5	

注 Remark:

1、本机用于无机房。The machine is used for machine roomless.

2、样本切口角为推荐值，可根据实际工况要求选择切口角度。The above is recommended value of cut angle, it's optional according to practical condition.