

MONA320

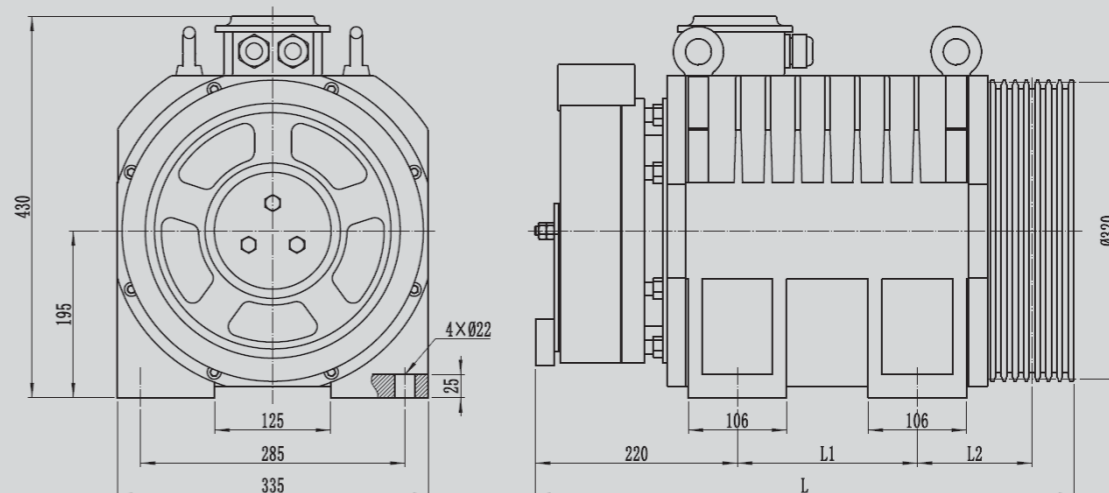

安装尺寸图
DIMENSIONS

Permanent Magnet Synchronous Gearless Traction Machine

永磁同步无齿轮曳引机

电源电压	Voltage	380V
悬挂比	Roping	2:1
绕绳方式	Wrap	单绕(Single)
额定载重	Elv. Load	630-1150kg
电梯速度	Elv. Speed	0.5-1.75m/s
曳引轮节径	Sheave Diam	320mm
工作制	Duty	S5-40%ED
起动次数	Starts Per Hour	180st/h
最大轴静载	Max. Static Load	3500kg
自重	Weight	300kg
制动器	Brake	DC110V 2.6A
防护等级	IP Code	IP41
绝缘等级	Ins. Class	F

规格表 / SPEC. SHEET

型号	规格	电梯载重	额定梯速	曳引轮直径	曳引轮绳槽	额定电流	额定功率	额定转速	额定频率	额定转矩	电机极数	L	L1	L2	推荐切口角
Type	Spec	Elv Load	Elv Speed	Sheave Dia	Sheave Groove	Current	Power	Speed	Freq	Torque	Poles	mm	mm	mm	Undercut Angle
		kg	m/s	mm		A	kW	r/min	Hz	N.m					°
MONA320	630-0.5	630	0.5	320	5×Φ8×12	7	2.1	60	12.0	340	24	550	154	124.5	90
MONA320	630-0.63	630	0.63	320	5×Φ8×12	7	2.7	75	15.0	340	24	550	154	124.5	
MONA320	630-1.0	630	1.0	320	5×Φ8×12	10	4.2	119	23.8	340	24	550	154	124.5	
MONA320	630-1.5	630	1.5	320	5×Φ8×12	16	6.4	179	35.8	340	24	550	154	124.5	
MONA320	630-1.6	630	1.6	320	5×Φ8×12	16	6.8	191	38.2	340	24	550	154	124.5	
MONA320	630-1.75	630	1.75	320	5×Φ8×12	16	7.4	209	41.8	340	24	550	154	124.5	
MONA320	800-0.5	800	0.5	320	6×Φ8×12	9	2.7	60	12.0	430	24	550	154	124.5	90
MONA320	800-0.63	800	0.63	320	6×Φ8×12	9	3.4	75	15.0	430	24	550	154	124.5	
MONA320	800-1.0	800	1.0	320	6×Φ8×12	13	5.4	119	23.8	430	24	550	154	124.5	
MONA320	800-1.5	800	1.5	320	6×Φ8×12	20	8.1	179	35.8	430	24	550	154	124.5	
MONA320	800-1.6	800	1.6	320	6×Φ8×12	20	8.6	191	38.2	430	24	550	154	124.5	
MONA320	800-1.75	800	1.75	320	6×Φ8×12	20	9.4	209	41.8	430	24	550	154	124.5	
MONA320	1000-0.5	1000	0.5	320	7×Φ8×12	11	3.4	60	12.0	540	24	590	194	124.5	85
MONA320	1000-0.63	1000	0.63	320	7×Φ8×12	11	4.2	75	15.0	540	24	590	194	124.5	
MONA320	1000-1.0	1000	1.0	320	7×Φ8×12	16	6.7	119	23.8	540	24	590	194	124.5	
MONA320	1000-1.5	1000	1.5	320	7×Φ8×12	25	10.1	179	35.8	540	24	590	194	124.5	
MONA320	1000-1.6	1000	1.6	320	7×Φ8×12	25	10.8	191	38.2	540	24	590	194	124.5	
MONA320	1000-1.75	1000	1.75	320	7×Φ8×12	25	11.8	209	41.8	540	24	590	194	124.5	
MONA320	1150-0.5	1150	0.5	320	8×Φ8×12	12	4	60	12.0	630	24	602	194	130.5	85
MONA320	1150-0.63	1150	0.63	320	8×Φ8×12	12	4.9	75	15.0	630	24	602	194	130.5	
MONA320	1150-1.0	1150	1.0	320	8×Φ8×12	18	7.9	119	23.8	630	24	602	194	130.5	
MONA320	1150-1.5	1150	1.5	320	8×Φ8×12	30	11.8	179	35.8	630	24	602	194	130.5	
MONA320	1150-1.6	1150	1.6	320	8×Φ8×12	30	12.6	191	38.2	630	24	602	194	130.5	
MONA320	1150-1.75	1150	1.75	320	8×Φ8×12	30	13.8	209	41.8	630	24	602	194	130.5	

注 Remark:

1、本机用于无机房。The machine is used for machine roomless.

2、样本切口角为推荐值，可根据实际工况要求选择切口角度。The above is recommended value of cut angle, it's optional according to practical condition.